



**memmert**  
Experts in Thermostatics

# HPPlife

## SUPPLEMENT TO THE OPERATING MANUAL CONSTANT CLIMATE CHAMBER HPP

ANIMAL KEEPING CHAMBER HPPlife

100% ATMOSAFE. MADE IN GERMANY.

[www.memmert.com](http://www.memmert.com) | [www.atmosafe.net](http://www.atmosafe.net)

## Manufacturer and customer service

MEMMERT GmbH + Co. KG  
Willi-Memmert-Straße 90-96  
91186 Büchenbach  
Germany

Phone: +49 (0)9122 925-0  
Fax: +49 (0)9122 14585  
E-mail: [sales@memmert.com](mailto:sales@memmert.com)  
Internet: [www.memmert.com](http://www.memmert.com)

### Customer service:

Service hotline: +49 (0)9171 9792 911  
Service fax: +49 (0)9171 9792 979  
E-mail: [service@memmert.com](mailto:service@memmert.com)

For service enquiries, please always specify the appliance number given on the type plate.

### Shipping address for repairs:

Memmert GmbH + Co. KG  
Customer service  
Willi-Memmert Str. 90-96  
91186 Büchenbach  
Germany

Please contact our customer service department before sending appliances for repair or before returning equipment, or the shipment may be refused.

© 2018 MEMMERT GmbH + Co. KG

D32802 | Date 11/2018

Subject to change without notice

## About this manual

---

### Purpose and target audience

This is a supplement to the operating instructions for the constant climate chamber HPP. This supplement amends the respective sections in the operating manual. If a specific section is not mentioned in this supplement, no changes are made to that section in the operating manual.

The supplement describes the special functions of the animal keeping chamber HPPlife and is intended for use by trained personnel of the owner, who have the task of operating and/or maintaining the respective appliance.

If you are asked to work on the appliance, read these instructions and the operating manual for the constant climate chamber HPP carefully before starting. Familiarise yourself with the safety regulations. Only perform work that is described in this manual. If there is something you do not understand, or certain information is missing, ask your manager or contact the manufacturer. Do not do anything without authorisation.

### Versions

The functions described in this manual refer to the latest firmware version.

Due to individual configurations and sizes, illustrations in this manual may be slightly different from the actual appearance. Function and operation are identical.

### Other documents that have to be observed:

- ▶ The operating manual for the constant climate chamber HPP
- ▶ For operation of the appliance with MEMMERT AtmoCONTROL, observe the separate software manual
- ▶ For service and repair work, observe the separate service manual

### Storage and resale

This operating manual belongs with the appliance and should always be stored where persons working on the appliance have access to it. It is the owner's responsibility to ensure that persons who are working on or are going to work on the appliance know where to find the operating manual. We recommend that it is always stored in a protected location close to the appliance. Make sure that the operating manual is not damaged by heat or humidity. If the appliance is resold or transported and then set up again at a different location, the operating manual must remain with it.

For the current version of this operating manual in PDF format, please go to <http://www.memmert.com/en/service/downloads/user-manual/>.

# Contents

---

<b>1. Safety regulations</b>	<b>5</b>
1.1 Terms and signs used.....	5
1.1.1 Terms used .....	5
1.1.2 Signs used .....	5
1.2 Product safety and dangers .....	5
1.3 Requirements of the operating personnel .....	6
1.4 Responsibility of the owner.....	6
1.5 Intended use.....	6
1.6 Changes and alterations.....	7
1.7 Behaviour in case of malfunctions and irregularities.....	7
1.8 Switching off the appliance in an emergency .....	7
<b>2. Description and function</b>	<b>8</b>
2.1 Description.....	8
2.2 Working range.....	8
2.3 Technical data .....	9
2.4 Scope of delivery .....	9
<b>3. Putting into operation</b>	<b>10</b>
3.1 Assembling the exhaust air unit.....	10
3.2 Connecting the appliance .....	11
3.2.1 Power and water.....	11
3.2.2 Compressed air .....	11
3.3 Switching on the appliance.....	11
<b>4. Operation and control</b>	<b>12</b>
4.1 ControlCOCKPIT.....	12
4.2 Adjustment options.....	13
4.3 Setting compressed air dehumidification .....	13
4.4 Example day-night simulation programme .....	14

# 1. Safety regulations

## 1.1 Terms and signs used







In this manual and on the appliance itself, certain common terms and signs are used to warn you of possible dangers or to give you hints that are important in avoiding injury or damage. Observe and follow these notes and regulations to avoid accidents and damage. These terms and signs are explained below.

### 1.1.1 Terms used

**"Warning"** is used whenever you or somebody else could be injured if you do not observe the accompanying safety regulation.

**"Caution"** is used for information that is important to avoid damage.

### 1.1.2 Signs used

Signs used					
					
Danger of electrocution	Danger of explosion	Dangerous gases/vapours	Disconnect the mains plug	Observe information in separate manual	Important or useful additional information

## 1.2 Product safety and dangers

The appliances described in this manual are technically sophisticated, manufactured using high-quality materials and subject to many hours of testing in the factory. They reflect the state of the art and comply with recognised technical safety regulations. However, there are still risks involved, even when the appliances are used as intended. These are described below.



**Warning!** After removing covers, live parts may be exposed. Touching these can lead to an electrical shock. Disconnect the mains plug before removing any covers. Work on the electrical system must only be performed by qualified electricians.



**Warning!** When loading the appliance with an unsuitable load, poisonous or explosive vapours or gases may be produced. This could cause the appliance to explode, and people could be severely injured or poisoned. The appliance may only be loaded with materials/test objects which do not release any toxic or explosive vapours when heated (see also chapter Intended use on page 6).



### 1.3 Requirements of the operating personnel

The appliance may only be operated and maintained by persons who are of legal age and have been instructed accordingly and have the qualifications required for working with experimental animals in accordance with the respective national and international regulations and laws on keeping and working with experimental animals.

Repairs may only be performed by qualified electricians. The regulations in the separate service manual must be observed.

### 1.4 Responsibility of the owner

The owner of the appliance

- ▶ is responsible for the flawless condition of the appliance and for it being operated in accordance with its intended use (see page 6);
- ▶ is responsible for ensuring that any persons operating or maintaining the appliance
  - have the required technical knowledge,
  - were instructed on the appliance and are familiar with the operating manual at hand as well as with the operating manual for the constant climate chamber HPP and
  - comply with the provisions of the respective national and international regulations and laws on keeping and working with experimental animals.
- ▶ must know about the applicable standards, requirements, operational safety regulations and animal welfare guidelines, and train staff accordingly;
- ▶ is responsible for ensuring that the relevant provisions for working with experimental animals are complied with;
- ▶ is responsible for ensuring that unauthorised persons have no access to the appliance;
- ▶ is responsible for ensuring that the maintenance plan is adhered to and that maintenance work is carried out properly (see operating manual constant climate chamber HPP);
- ▶ has to ensure that the appliance and its surroundings are kept clean and tidy, for example through corresponding instructions and inspections;
- ▶ is responsible for ensuring that personal protective clothing is worn by operating personnel, e.g. work clothes, safety shoes and protective gloves.

### 1.5 Intended use

The animal keeping chamber HPPlife is intended for the keeping of laboratory mice. Only use it in accordance with the provisions of the respective national and international regulations and laws on keeping and working with experimental animals.

The appliance is not explosion-proof (does not comply with the German occupational health and safety regulation VBG 24). The appliance may not be loaded with materials and substances which can release any toxic or explosive vapours at the set temperature or which can explode, burst or ignite.

The appliance may not be used for the drying, evaporation and burning-in of paints or similar materials, the solvents of which could form an explosive mixture when combined with air. If there is any doubt as to the composition of materials, they must not be loaded into the appliance. Potentially explosive gas-air mixtures must not form, neither in the chamber nor in the direct vicinity of the appliance.

## 1.6 Changes and alterations

No unauthorised changes or alterations may be made to the appliance. No parts may be added or inserted which have not been approved by the manufacturer.

Unauthorised changes or alterations result in the CE declaration of conformity losing its validity, and the appliance may no longer be operated.

The manufacturer is not liable for any damage, danger or injuries that result from unauthorised changes or alterations, or from non-compliance with the provisions in this manual.

## 1.7 Behaviour in case of malfunctions and irregularities

The appliance may only be used in a flawless condition. If you as the operator notice irregularities, malfunctions or damage, immediately take the appliance out of service and inform your superior.

## 1.8 Switching off the appliance in an emergency

Press the main switch at the ControlCOCKPIT (Fig. 1) and disconnect the power plug. This disconnects the appliance from the power supply at all poles.

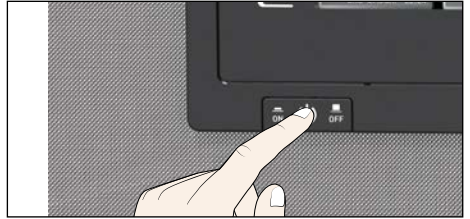

*Fig. 1*  
*Switch off the appliance by pressing the main switch*

## 2. Description and function

### 2.1 Description

The appliance can heat the interior up to 70 °C and cool it down to 0 °C. In addition to the HPP standard equipment, the appliance features an exhaust fan in the back of the chamber and 4 swivel-type LED light strips for adjusting the interior lighting in steps of 1 %. HPPlife appliances have more humidity. Therefore, use the central compressed air dehumidification (see page 13).

### 2.2 Working range

The temperature-humidity diagram (Fig. 2) specifies at what range of temperature and humidity a permanent, condensation-free operation is possible.

**i Caution:** Always observe the indicated humidity-temperature range. Otherwise, puddles may form in the chamber and leak through the door seal.

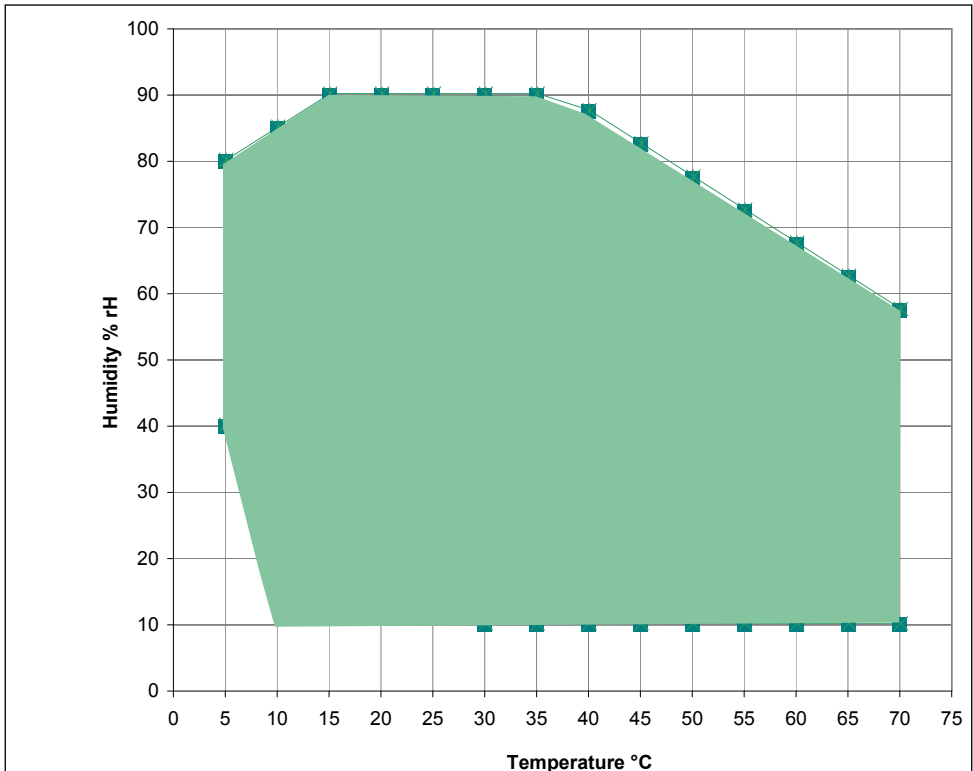

Fig. 2 Temperature-humidity working range of animal keeping chambers HPPlife



## 2.3 Technical data

Appliance width [mm]		1225
Appliance height [mm]		1720
Appliance depth [mm]		856
Depth of door lock [mm]		56
Appliance depth (including door handle) [mm]		930
Chamber width [mm]		1040
Chamber height [mm]		1200
Chamber depth [mm]		600
Chamber volume [litres]		749
Weight (in the box) [kg]		284
Power [W]		1500
Current consumption [A]	230 V, 50/60 Hz	6.5
	115 V, 50/60 Hz	13
max. number of sliding grids		max. 3 illuminated
max. load per sliding grid [kg]		30
max. load per appliance [kg]		200
Temperature	Adjustment range	0 °C to +70 °C
	Working range with illumination	+5 °C to +40 °C
	Adjustment precision	0.1 K
Humidity	Adjustment range	10 ... 90 % rh
LED lighting		5,500 K cold white and 2,700 K warm white, radiating upwards (swivel-type)

## 2.4 Scope of delivery

- ▶ Exhaust air unit
- ▶ 18 Torx screws M3x8
- ▶ Back of the chamber
- ▶ Assembly instructions



For more information on the design and description and on delivery and setting up, please refer to the operating manual for the constant climate chamber HPP.

### 3. Putting into operation

#### 3.1 Assembling the exhaust air unit



**Warning! Danger to life due to electric shock. When assembling the exhaust air unit, the chamber must not be connected to the power supply.**

1. Plug the connector of the exhaust air unit into the cable socket on the back of the appliance (Fig. 3, 1). Stow away the cable in the housing of the exhaust air unit (2).
2. Insert the exhaust air unit with the pipe socket into the entry port in the back of the chamber (Fig. 4) and attach it to the chamber with the eight Torx screws included (Fig. 5). Make sure that the exhaust pipe points upwards (Fig. 6).

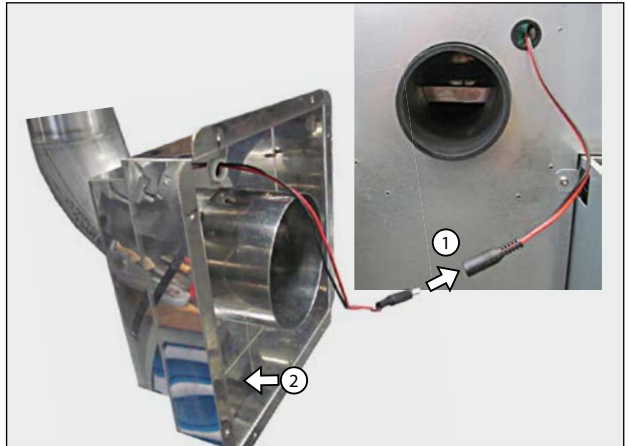

Fig. 3 Connect the leads



Fig. 4 Insert the exhaust air unit in the back of the chamber



Fig. 5 Screw the exhaust air unit tight



Fig. 6 The exhaust pipe needs to point up

3. Remove the three silicone plugs that are located at the centre and at the lower left and right of the interior.

## 3.2 Connecting the appliance

### 3.2.1 Power and water

Connect the appliance to the power and water supply as described in the operating manual for the constant climate chamber HPP.

### 3.2.2 Compressed air



**Warning! Only connect compressed air to the gas connection on the back of the appliance. Introducing other gases or substances can cause severe damage and considerable danger (explosion or poisoning).**

Use a suitable pressure hose to connect the chamber to an external compressed air supply (max. 5 bar) at the rear of the appliance (Fig. 7).

- Only oil-free compressed air may be used.

See page 13 to see instructions on how to set compressed air dehumidification.

## 3.3 Switching on the appliance

Switch on the appliance by pressing the main switch on the front of the appliance (Fig. 8).

- The appliance displays are in English by default when the appliance is switched on for the first time. You will find instructions as to how to change the language in the operating instructions of the constant climate chamber HPP.

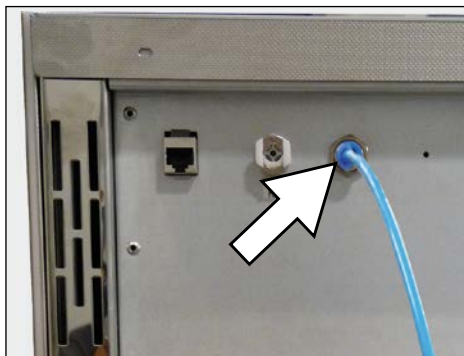

Fig. 7 Compressed air connection (max. 5 bar)

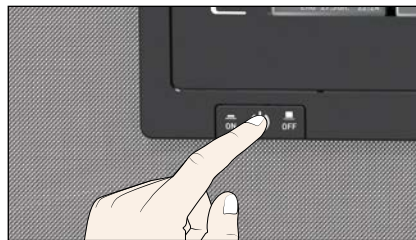

Fig. 8 Switching on the appliance

## 4. Operation and control

Only use the appliance in accordance with the national and international regulations and laws on keeping and working with experimental animals. The appliance may only be operated by persons who have the required qualifications for working with experimental animals.



This chapter only describes the special functions of the HPPlife appliance. You must read the operating manual for the constant climate chamber HPP (standard model) to familiarise yourself with the basic operation and the operating modes.

### 4.1 ControlCOCKPIT

In addition to the standard functions, you can set the speed of the exhaust air fan on the back of the chamber in the ControlCOCKPIT of the HPPlife appliance.

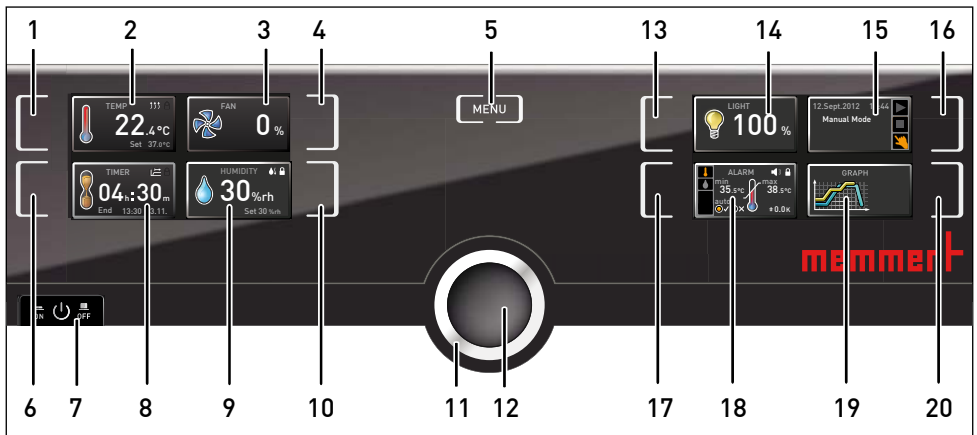

Fig. 9 ControlCOCKPIT of HPPlife appliances in operating mode



- |   |  |
|---|--|
| <ol style="list-style-type: none"> <li>1 Activation key for temperature setpoint adjustment</li> <li>2 Setpoint and actual temperature display</li> <li>3 Fan speed display</li> <li>4 Activation key for fan speed setting</li> <li>5 Changing to the menu mode (see operating manual constant climate chamber HPP)</li> <li>6 Activation key for timer setting</li> <li>7 Main switch</li> <li>8 Timer display</li> <li>9 Humidity control display</li> <li>10 Humidity control activation key</li> </ol> | <ol style="list-style-type: none"> <li>11 Turn control for setpoint adjustment</li> <li>12 Confirmation key (accepts setting made with the turn control)</li> <li>13 Activation key for LED interior lighting setting</li> <li>14 Display LED interior lighting</li> <li>15 Appliance state and programme display</li> <li>16 Activation key for the appliance state</li> <li>17 Activation key setting the temperature and humidity monitoring</li> <li>18 Monitoring display</li> <li>19 Graphical representation</li> <li>20 Activation key for graphical representation</li> </ol> |
|---|--|

## 4.2 Adjustment options

You can set the following parameters after pressing the corresponding activation key (in any sequence):

### Temperature

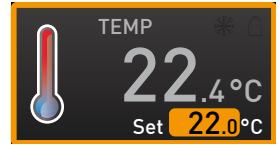

Adjustment range: 0 to 40 °C

-  Heating operation is indicated by the ↑↑↑ symbol.
-  Cooling is indicated by the \* symbol.



### Humidity

Adjustment range: 10 to 90 % rh

-  Humidification is indicated by the ⬆️ symbol.
-  Dehumidification is indicated by the ⬇️ symbol.

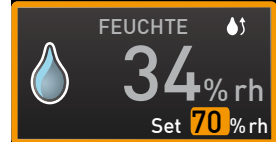

### LED interior lighting

Adjustment range: 0 to 100 % in steps of 1%



### Fan speed

Adjustment range: 0 to 100 % in steps of 10%

-  Make sure that no draught forms in the interior due to the settings.



Please refer to the operating manual for the constant climate chamber HPP for the adjustment options of the timer, the programme operation, temperature and humidity monitoring, the graphical representation and the menu functions.

## 4.3 Setting compressed air dehumidification

The compressed air cannot be dehumidified with the ControlCOCKPIT. Use the pressure controller (Fig. 12) instead. For best results when dehumidifying compressed air, set the humidity range so that it fluctuates around the setpoint with the smallest amplitude possible. Use the ControlCOCKPIT (Display "Graph") or the AtmoCONTROL software to track the relative humidity in the appliance (Fig. 10 and Fig. 11).

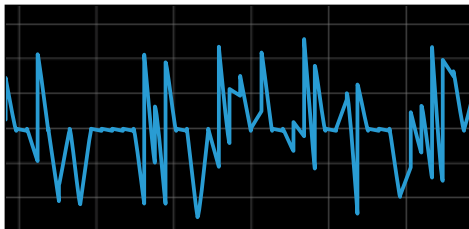

Fig. 10 Incorrect operating pressure (high humidity fluctuation)

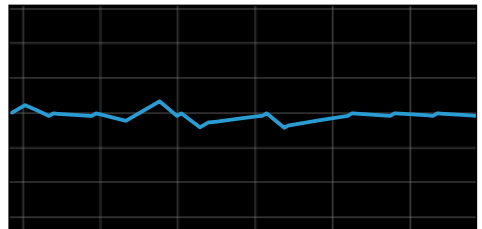

Fig. 11 Correct operating pressure (small humidity fluctuation)

A test under real conditions helps you set the operating pressure needed to dehumidify the compressed air.

To change the operating pressure, pull the plastic cap under the manometer of the pressure controller down until you see the orange sheathing (Fig. 12).

- ▶ Turn the cap clockwise to reduce the operating pressure;
- ▶ Turn the cap counter-clockwise to increase the operating pressure.

Increase or decrease the operating pressure with the pressure controller until you've reached the smallest humidity amplitude possible (Fig. 11).

- When you change the operating pressure, you will not immediately see this change in the humidity range graph. Let the appliance run with the new settings for about 15 minutes. Then the adjustment will show on the graph correctly.



Fig. 12 Pressure controller

The operating pressure for compressed air dehumidification set in the factory is 0.2 bar. This is enough to achieve a certified dehumidification of 10 % humidity at 10 °C under laboratory conditions. You can adjust the operating pressure after testing the appliance under the operating conditions with parameters of your choice. The following parameters may have a negative effect on constant regulation:

- ▶ User-defined composition of the temperature-humidity parameters
- ▶ User-defined dehumidification rate
- ▶ Humidity that was introduced into the chamber

Manually readjust compressed air dehumidification if you use the appliance for a different purpose.

- We do not recommend using the compressed air dehumidification function in an application range other than the one described above.

### 4.4 Example day-night simulation programme

With the help of the MEMMERT software AtmoCONTROL, programme-controlled operation of the appliance is possible. On the following page, you see an example as to how day/night cycles can be simulated.



You must read the software manual AtmoCONTROL in order to acquaint yourself with the programme.

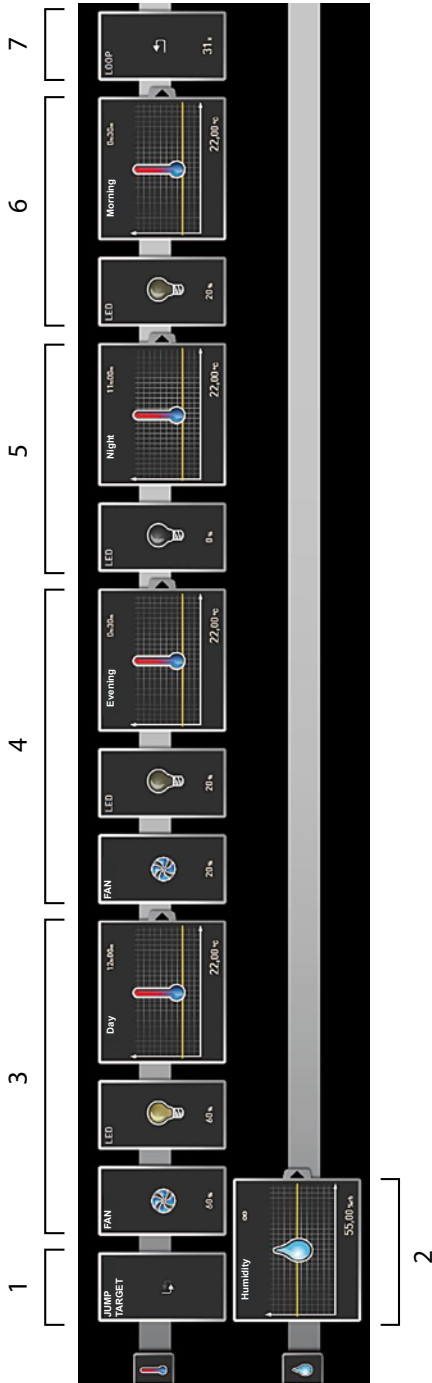

Fig. 13 Simulated day/night cycle in the AtmoCONTROL programming software (example)

- 1 Jump target for the daily repetition of the programme when reaching LOOP (7)
- 2 55 % relative humidity during the entire time<sup>(∞)</sup>
- 3 Day simulation: 60 % fan speed, 60 % LED lighting and 22 °C for 12 hours
- 4 Evening simulation: 20 % fan speed, 20 % LED lighting and 22 °C for 30 minutes
- 5 Night simulation: 0 % LED lighting and 22 °C for 11 hours with unchanged fan speed of 20 %
- 6 Morning simulation: 20 % LED lighting and 22 °C for 30 minutes with unchanged fan speed of 20 %
- 7 Jump back to 1 and repetition of the programme from 3 (31 times)



**memmert**  
Experts in Thermostatics

Animal keeping chamber HPPlife

D32802 | Date 11/2018

English

Memmert GmbH + Co. KG  
Willi-Memmert-Straße 90-96 | D-91186 Büchenbach  
Tel. +49 9122 925-0 | Fax +49 9122 14585  
E-Mail: [sales@memmert.com](mailto:sales@memmert.com)  
[facebook.com/memmert.family](https://facebook.com/memmert.family)  
Die Experten-Plattform: [www.atmosafe.net](http://www.atmosafe.net)